

AE/AF系列减速机 AE/AF SERIES GEAR BOX

剖视图 Sectional Drawing

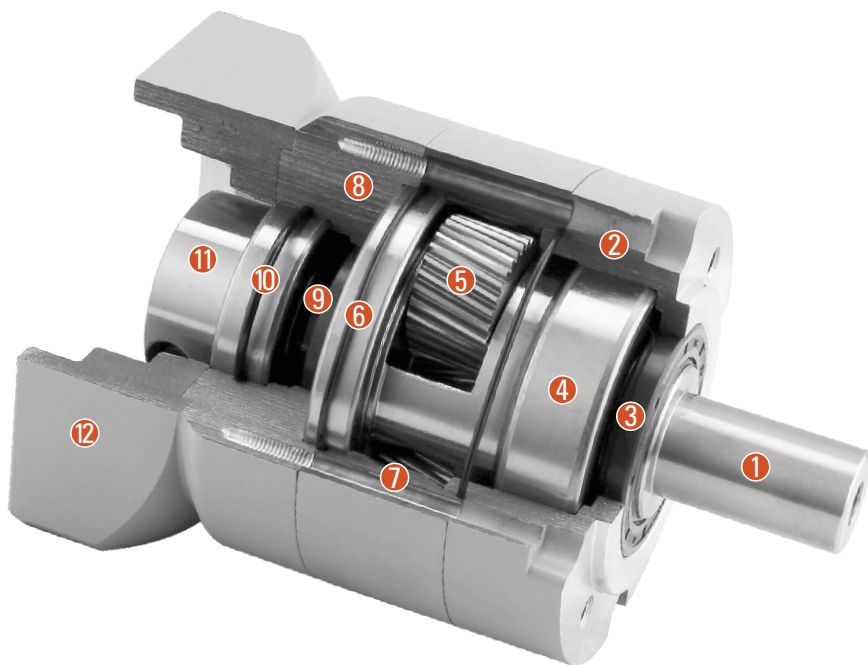

- ① 输出轴 Output shaft
- ② 前盖 Front cover
- ③ 油封 Oil seal
- ④ 输出轴前轴承 Output shaft front bearing
- ⑤ 行星轮 Planetary gear
- ⑥ 输出轴后轴承 Output shaft rear bearing
- ⑦ 内齿轮 Front cover
- ⑧ 后盖 Rear cover
- ⑨ 太阳轮 Solar wheel
- ⑩ 联轴器轴承 Coupling
- ⑪ 联轴器 Coupling
- ⑫ 适配电机法兰 Rear cover

系列号、机座标识说明 Type And Model Number

AE/F减速机 AE/F Reducers				伺服电机 Servo Motor		
60	AE/F	10	()	(S)	- 400	T1
①	②	③	④	⑤	⑥	⑦
① 减速机机座号: 060 减速机系列代号: ② AE: 圆形安装法兰系列 AF: 方形安装法兰系列				Gear head frame size: 060 Gear head series code: Round mounting flange series Square mounting flange series		
③ 减速比: 10				Gear ratio: Single stage 10		
④ 精度 Accuracy 输出轴负荷量为容许输出扭矩的±3%时的值 Output shaft load value at ±3% of allowable output torque				机座号 Cabin seat	级数 Series	标准型 (省略) Standard (omitted)
				60AE/F	1	5
				90AE/F	2	7
				120AE/F	1	5
⑤ 输入轴型式 S: 整体锁紧 (省略) (无论马达是否有键槽都可使用) S1: 带锁紧环锁紧 (无论马达是否有键槽都可使用) S2: 带键槽锁紧 (输入轴带键) K: 带键槽 A: 其他适配器 (请于本公司联系)				Input shaft type S: Overall locking (Omitted) (Can be used regardless of whether the motor has a keyway) S1: Locking with locking ring (Can be used regardless of whether the motor has a keyway) S2: Lock with keyway (Input shaft with key) K: With keyway A: Other adapters (Please contact us)		
				⑥ 适用伺服马达功率(W) Applicable servo motor power (W)		
⑦ 输入法兰与伺服电机对应尺寸表 ()				Corresponding dimension table of input flange and servo motor ()		

AE/AF系列精密行星减速机

AE/AF PLANETARY GEAR BOX

技术资料 Dimensional Drawing

产品型号 Product type		60	90	120	减速比 Reduction ratio	级数 Series
额定输出扭矩 Rated output torque	N.M	34	85	144	3	1
		33	95	200	4	
		38	105	220	5	
		36	93	200	7	
		30	83	180	8	
		26	70	155	10	
		48	115	209	12	2
		48	115	209	15	
		47	130	275	16	
		47	130	275	20	
		50	135	280	25	
		45	120	260	32	
		45	125	265	35	
		43	115	245	40	
		50	135	280	50	
		37	83	180	64	
		32	83	180	80	
29	73	165	100			
寿命 life	小时 Hour	20000				
瞬间急停扭矩 Instant emergency stop torque	N.M	2倍额定输出力矩 2 times rated output torque				

产品型号 Product type	60	90	120	单位 Company	级数 Series
最大径向力 Radial force	750	2100	2520	N	-
最大轴向力 Axial force	375	1050	1260	N	-
满载效率 Full load efficiency	≥97			%	1
	≥94				2
重量 Weight	0.9	2.5	6.5	Kg	1
	1.2	3.0	7.2		2
工作温度 Operating temperature	-10~+90			°C	-
保护等级 Protection level	IP65				
润滑方式 Lubrication method	终身润滑 Lifetime lubrication				
安装方式 Installation method	任意 Any				

最大径向力与最大轴向力，输出100RPM时，作用于输出轴中心位置(L/2)处。

Maximum radial force and maximum axial force, when the output is 100RPM, it acts on the center position (L / 2) of the output shaft.

AE/AF系列精密行星减速机 AE/AF PLANETARY GEAR BOX

■ 技术资料 Dimensional Drawing

产品型号 Product type		60	90	120	减速比 Reduction ratio	级数 Series
转动惯量 Moment of inertia	Kgcm ²	0.15	0.69	2.94	3	1
		0.12	0.50	2.27	4	
		0.10	0.46	2.10	5	
		0.10	0.42	2.00	7	
		0.10	0.42	2.00	8	
		0.09	0.39	1.90	10	
		0.06	0.32	1.50	12	2
		0.05	0.29	1.13	15	
		0.06	0.32	1.11	16	
		0.05	0.29	0.99	20	
		0.05	0.29	0.98	25	
		0.05	0.26	0.89	32	
		0.05	0.26	0.89	35	
		0.05	0.26	0.89	40	
		0.05	0.26	0.89	50	
		0.05	0.26	0.89	64	
		0.05	0.26	0.89	80	
		0.05	0.26	0.89	100	

产品型号 Product type		60	90	120	级数 Series
回程间隙 Backlash	arcmin	≤5	≤5	≤5	1级 One series
	弧分	≤8	≤8	≤8	2级 Two series
抗扭刚性 Torsion resistance	N.M/arcmin	1.8	4.5	12	-
噪声 Noise	dB(A)	63			-
最高输出转速 Output speed	min ⁻¹	4500	4500	4500	-
推荐输入转速 Recommended input speed	min ⁻¹	3000	3000	3000	-

1. 转动惯量与输入轴有关。Moment of inertia is related to input shaft.
2. 噪声检测标准，距离1m，在输入转速3000转/分空载时测得。Noise detection standard, distance 1m, measured at input speed of 3000 rpm with no load.

AE行星减速机-机械参数

AE PLANETARY GEAR BOX-MECHANICAL PARAMETER

尺寸图 Dimensional Drawing

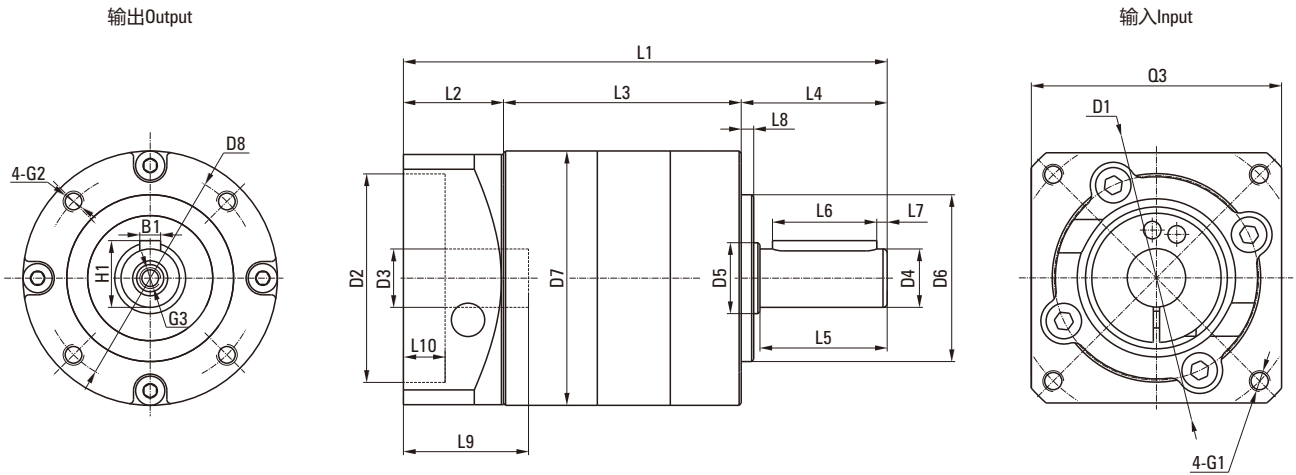

尺寸表 Dimensional Table

[单位Unit: mm]

产品型号 Product type	60AE		90AE		120AE	
级数 Number of stage	1	2	1	2	1	2
L1箱体总长 L1 overall length	116	126	151	165.5	196	207
L3箱体长度 L3 body length	57	67	77.3	91.8	93	104
输出端 Output						
L4出轴长度 L4 output shaft length	35		40		55	
L5出轴长至轴肩 L5 output length to the shaft shoulder	30.5		36		50	
L6键长度 L6 key length	25		28		40	
L7键至轴末端长 L7 key length to shaft end	2.5		4		5	
L8凸台直径 L8 spigot length	3		3		4	
D4出轴直径 D4 output shaft diameter	Φ14h7		Φ20h7		Φ25h7	
D5轴肩直径 D5 shaft shoulder diameter	Φ20		Φ30		Φ40	
D6定位凸台直径 D6 spigot length	Φ40h7		Φ60h7		Φ80h7	
D7箱体直径 D7 body diameter	Φ61		Φ90		Φ115	
D8安装孔分布圆 D8 hole circle	Φ52		Φ70		Φ100	
B1键宽 B1 key width	5		6		8	
H1键高 H1 key height	16		22.5		28	
G2安装螺纹孔 G2 mounting screw hole	M5X10		M6X12		M10X16	
G3中心螺纹孔 G3 center screw hole	M5X15		M6X18		M10X22	
输入端 Input						
L2输入端法兰长度 L2 input flange length	24		33.7		48	
L9电机轴长度 L9 motor shaft length	30		40		58	
L10定位凸台深 L10 spigot depth	10		10		10	
D1安装孔分布圆 D1 mounting hole distribution circle	Φ70		Φ90		Φ145	
D2定位凸台直径 D2 spigot diameter	Φ50G7		Φ70G7		Φ110G7	
D3输入轴轴径 D3 input shaft diameter	≤14G7		≤19G7		≤24G7	
G1安装螺纹孔X深度 G1 mounting threads X depth	M4X10		M5X12		M8X21	
Q3输入法兰 Q3 input flange	□60		□80		□130	

AF行星减速机-机械参数

AF PLANETARY GEAR BOX-MECHANICAL PARAMETER

尺寸图 Dimensional Drawing

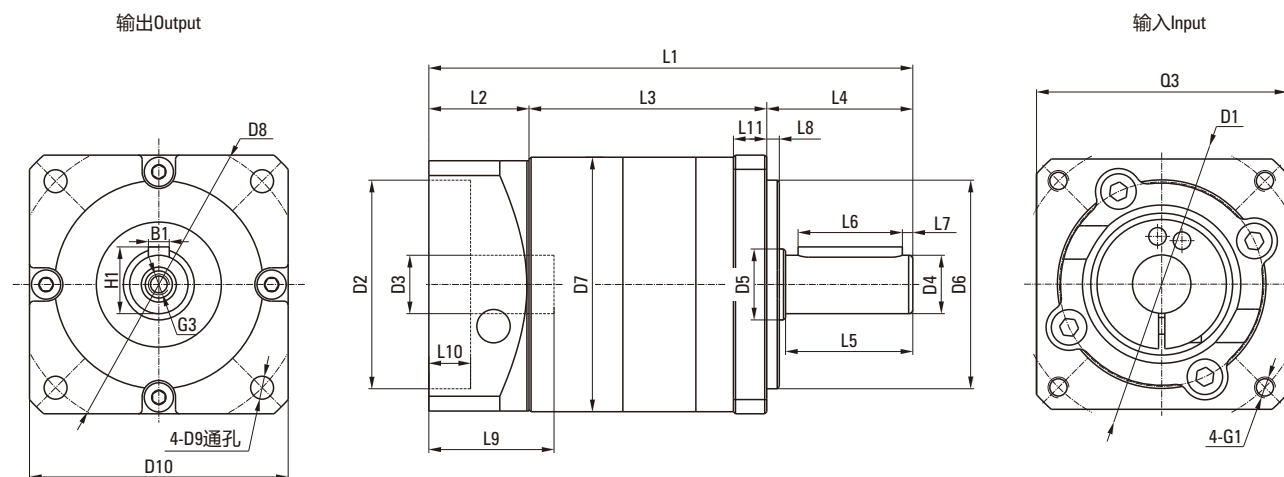

尺寸表 Dimensional Table

[单位Unit: mm]

产品型号 Product type	60AE		90AE		120AE	
级数 Number of stage	1	2	1	2	1	2
L1箱体总长 L1 overall length	116	126	151	165.5	196	207
L3箱体长度 L3 body length	57	67	77.3	91.8	93	104
输出端 Output						
L4出轴长度 L4 output shaft length	35		40		55	
L5出轴长至轴肩 L5 output length to the shaft shoulder	30.5		36		50	
L6键长度 L6 key length	25		28		40	
L7键至轴末端长 L7 key length to shaft end	2.5		4		5	
L8凸台直径 L8 spigot length	3		3		4	
D4出轴直径 D4 output shaft diameter	Φ14h7		Φ20h7		Φ25h7	
D5轴肩直径 D5 shaft shoulder diameter	Φ20		Φ30		Φ40	
D6定位凸台直径 D6 spigot length	Φ50h7		Φ80h7		Φ110h7	
D7箱体直径 D7 body diameter	Φ61		Φ90		Φ115	
D8安装孔分布圆 D8 hole circle	Φ70		Φ100		Φ130	
D9法兰安装孔 D9 mounting hole	Φ5.5		Φ6.5		Φ8.5	
D8安装孔分布圆 D8 hole circle	□62		□90		□115	
B1键宽 B1 key width	5		6		8	
H1键高 H1 key height	16		22.5		28	
G3中心螺纹孔 G3 center screw hole	M5X15		M6X18		M10X22	
输入端 Input						
L2输入端法兰长度 L2 input flange length	24		33.7		48	
L9电机轴长度 L9 motor shaft length	30		40		58	
L10定位凸台深 L10 spigot depth	10		10		10	
D1安装孔分布圆 D1 mounting hole distribution circle	Φ70		Φ90		Φ145	
D2定位凸台直径 D2 spigot diameter	Φ50G7		Φ70G7		Φ110G7	
D3输入轴轴径 D3 input shaft diameter	≤14G7		≤19G7		≤24G7	
G1安装螺纹孔X深度 G1 mounting threads X depth	M4X10		M5X12		M8X21	
Q3输入法兰 Q3 input flange	□60		□80		□130	

伺服电机对应尺寸表 SERVO MOTOR CORRESPONDING SIZE TABLE

减速器输入端 Gearbox Input

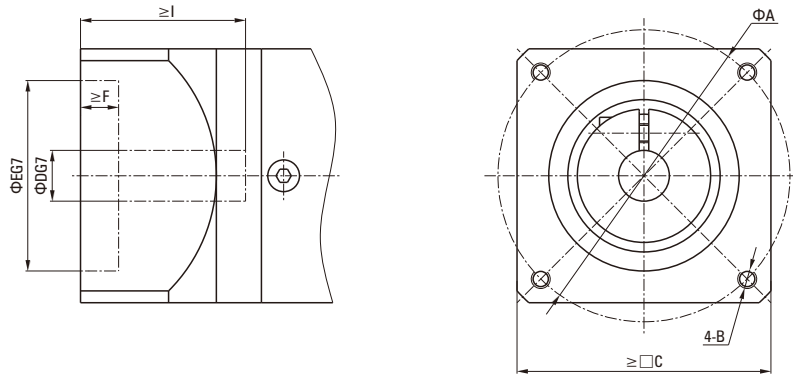

输入法兰与伺服电机对应尺寸表 Input Flange And Servo Motor Matching Table

电机功率 Motor Power (W)	电机尺寸 Motor Size	安装距 Installation Distance	螺纹孔 Threaded Hole	边框 Frame	孔径 Aperture	止口 Stop	止口深度 Stop Depth	轴伸 Shaft Extension
		A	B	C	D	E	F	I
50	T1	45	M3	38	8	30	3	25
	T2	46	M4	40	6	30	3	25
	T3	47	M4	40	8	30	3	25
	T4	48	M3	42	8	30	3	25
100	T1	45	M3	38	8	30	3	25
	T2	46	M4	40	8	30	3	25
	T3	46	M4	40	8	30	3	25
	T4	48	M3	42	8	30	3	25
200	T1	70	M4	60	11	50	3	30
	T2	70	M5	60	14	50	3	30
	T3	70	M5	60	14	50	3	30
400	T1	70	M4	60	14	50	3	30
	T2	70	M5	60	14	50	3	30
	T3	70	M5	60	14	50	3	30
750	T1	90	M5	80	19	70	3	35
	T2	90	M6	80	16	70	3	40
	T3	90	M6	80	19	70	3	40
	T4	100	M6	86	16	80	3	35
	T5	145	M8	130	19	110	6	58
	T6	100	M6	86	19	80	3	40
1000	T1	100	M6	90	19	80	3	55
	T2	115	M6	100	24	95	3	45
	T3	115	M8	100	24	95	5	45
	T4	145	M8	130	22	110	6	58
	T5	145	M8	130	22	110	6	70
	T6	115	M8	100	22	95	5	45
	T7	145	M8	130	24	110	3	55
1500	T1	115	M8	100	19	95	3	55
	T2	115	M6	100	24	95	3	45
	T3	115	M8	100	24	95	3	45
	T4	145	M8	130	22	110	6	58
	T5	145	M8	130	22	110	6	70
	T6	115	M8	100	22	95	5	45
	T7	145	M8	130	24	110	3	55

伺服电机对应尺寸表 SERVO MOTOR CORRESPONDING SIZE TABLE

输入法兰与伺服电机对应尺寸表 Input Flange And Servo Motor Matching Table

电机功率 Motor Power (W)	电机尺寸 Motor Size	安装距 Installation Distance	螺纹孔 Threaded Hole	边框 Frame	孔径 Aperture	止口 Stop	止口深度 Stop Depth	轴伸 Shaft Extension
		A	B	C	D	E	F	I
2000	T1	115	M8	100	19	95	3	55
	T2	115	M6	100	24	95	3	45
	T3	115	M8	100	24	95	3	45
	T4	145	M8	130	22	110	6	58
	T5	200	M12	130	35	114.3	10	80
	T6	115	M8	100	22	95	5	45
2500	T1	115	M8	100	19	95	3	55
	T2	115	M6	100	24	95	3	45
3000	T1	130	M8	120	22	110	3	55
	T2	145	M8	130	28	110	6	65
	T4	145	M8	130	24	110	6	65
	T5	200	M12	175	35	114.3	10	80
	T7	200	M12	175	35	114.3	10	65
3500	T1	130	M8	120	22	110	3	55
	T2	145	M8	130	28	110	3	63
	T5	200	M12	175	35	114.3	10	80
4000	T1	145	M8	130	24	110	6	65
	T2	145	M8	130	28	110	6	65
	T5	200	M12	175	35	114.3	10	80
	T6	200	M12	175	42	114.3	10	113
4500	T1	145	M8	130	24	110	6	65
	T5	200	M12	175	35	114.3	10	80
	T6	200	M12	175	42	114.3	10	113
	T7	200	M12	175	35	114.3	10	65
5000	T1	145	M8	130	24	110	6	65
	T2	145	M8	130	28	110	6	65
	T5	200	M12	175	35	114.3	10	80
	T7	200	M12	175	35	114.3	10	65

注1)没有油封和尺寸不同时，安装带油封的马达有时需特别订货。

If an oil-seal is not present and the size is different, attachment of the oil-seal may correspond to special order, in some cases.

注2)马达轴为D形轴、锥形时需要特别订货。

If the motor shaft is of D-cut and taper type, it corresponds to a special order.

注3)标准外有时需要特别订货。欲知详情，请另外与本公司联系。

Out-of-standard may correspond to a special order in some cases, For details, contact us.

■ 安装马达的步骤 Assembly Procedure

客户自行安装伺服马达时，请按以下要领进行安装。伺服马达的尺寸多种多样，除指定的产品外，有些马达可能会无法连接法兰，因为，一定要使用您订货时指定的马达。

If a customer personally assembles the servo motor and reducer please use the following tip. The reducer flange to which the servo motor is attached has different dimensions based on the motor specified. Therefore, assembly may be impossible for some motor. Make sure the correct motor is specified before ordering the reducer.

1. 安装无键马达 Spec. In Case Of Assembling A Motor Without Key

- ①取下橡胶帽，转动输入轴，使螺栓头和紧定螺钉的孔吻合。并确认固定螺栓已松开。
Take off the rubber cap, turn the input shaft, and match the head of the bolt to the hole of the rubber cap. Make sure that the set bolt is loosened.
- ②将马达轴平稳地插入输入轴（请确保不受阻塞地顺畅的插入）。请充分注意不要让马达倾斜插入。
Gradually put the motor shaft into the input shaft (Ensure that it is smoothly put in without iam.) Be careful not to be inserted with the motor tilted.
- ③将马达固定在减速机上，并按指定的扭矩将螺栓拧紧。参考表1
Attach the motor to the reducer and fasten the bolt with designated fastening torque. See Table 1.
- ④使用扭矩扳手等工具，按指定的扭矩将输入轴的固定螺栓拧紧。参考表2
Fasten the set bolt of the input shaft with designated fastening torque wrench, etc. See Table 2.
- ⑤盖上橡胶帽。安装到此结束。
Put on the rubber cap. It is the end of assembling.

● 表1 Table1

马达固定螺栓 Motor Combination Bolt	拧紧扭矩 Fastening Torque	
	(N·m)	(kgf·cm)
M3	1.0	10
M4	3.0	30
M5	5.8	60
M6	9.8	100
M8	19.6	200
M10	39.2	400
M12	68.6	700
M16	168	1650

● 表2 Table2

固定螺栓 Combination Bolt	拧紧扭矩 Fastening Torque	
	(N·m)	(kgf·cm)
M3	1.5	15
M4	3.5	35
M5	7.1	71
M6	12	120
M8	30	300
M10	60	612

带键槽式马达的键取下后，可以像上述无键马达一样安装。无需担心会滑动。
You can assemble the motor with keyway like above when take off the key. There is no risk of dislocation.

● AE/AF 系列示意图
AE/AF Series Schematic Diagram

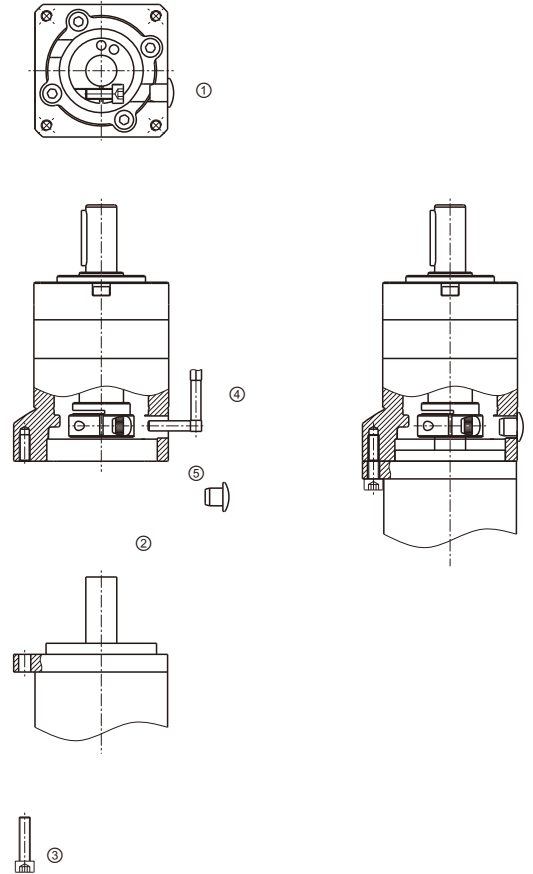

■ 减速机的安装 Reducer Assembly

将减速机安装在设备上时，请在确认安装面平坦且无毛刺等后，使用扭矩扳手等工具按指定的扭矩用螺栓将其固定。参考表4

Jointing with reducer In case of jointing a reducer with the device, make sure that the combining side is plane without inconsistency, and when assemble reducer outo equipment, ensuring assembly surface smooth and without burr. See Table 4.

● 表4 Table4

减速机固定螺栓 Reducer Combination Bolt	拧紧扭矩 Fastening Torque	
	(N·m)	(kgf·cm)
M5	5.8	60
M6	9.8	100
M8	19.6	200
M10	39.2	400
M12	68.6	700
M16	16.8	1650

■ 连接输出轴 Connection To The Output Shaft

注意事项 Cautions:

- 1、在输出轴上安装耦合器、滑轮等时，请勿在输出轴上施加过大的轴向负荷。
When assemble a coupling, pulley, etc. onto the output shaft, make sure that excessive axial load not be given to the output shaft.
- 2、请勿使用强力将轴敲入，以免使轴承或减速机内部受到损伤。
In case of strongly hitting the shaft with a hammer, the shaft inlet or the inside of the reducer may be damaged, therefore it shall be prohibited.
- 3、安装的耦合器等的轴和键槽如有较大松动，可能会导致设备烧毁，安装时请充分注意。
If the shaft or key of a coupling assembled is loosed, it may cause carbonization, so be careful when assembling.
- 4、安装耦合器等时，请使用固定螺栓来将键固定住。
For assembling of a coupling, fix the key with a set bolt.
- 5、连接时请充分调校轴心。 Please adjust shaft centre carefully in connecting.

